

# Cartridge Filter, Stationary

Art. No.: 83 200 109



## Technical Data

Filter	
Filter stages	1
Filter method	Cleanable filter
Filter cleaning method	Rotating nozzle
Filter surface	8 m <sup>2</sup>
Type of filter	Filter cartridge
Filter material	ePTFE membrane
Filter efficiency	> 99.9 %
Dust classification	M
Basic data	
Extraction capacity	2 x 700 m <sup>3</sup> /h
Max. fan performance	3000 m <sup>3</sup> /h
Dimensions (w x t x h)	655 x 655 x 1355 mm
Weight	142 kg
Motor power	1.5 kW
Power supply	3 x 400 V / 50 Hz
Rated current	3.5 A
Noise level	71 dB(A)
Additional information	
Fan type	Radial fan
Compressed air supply	5 - 6 bar
Quantity of extraction arms	2
Exhaust arm type	rigid metal tube arm
Diameter extraction arm	150 mm
Length of exhaust arm	5 m
Compressed air reservoir	25 l
Capacity Dust collection container	11 l

## Applications

- High levels of smoke and particles
- Non-stop operation
- Two exhaust arms available

## Benefits

- High efficiency due to automatic filter cleaning
- Less need to adjust the exhaust arm due to flow-optimised exhaust hood design
- Best health protection for employees by use of KemTex® ePTFE filter cartridges with surface filtration
- Low air consumption due to differential pressure-controlled cleaning
- Space-saving solution due to two extraction arms
- Possibility of working in two alternating places due to dampers in the extraction hood

## Properties

- 360 degrees rotating exhaust hood with damper
- Automatic filter cleaning, pressure-controlled
- KemTex® ePTFE filter cartridges
- Automatic Start-Stop (optional)
- Lighting in the hood (optional)
- Arm from 5 m with boom
- Available with two arms
- Silencer
- Control box

## Accessories

- Automatic start-stop
- Workplace lighting incl. on/off switch at the hood



Suitable for alveole exchangeable dusts  
separation > 99 % of particles < 0.4 µm

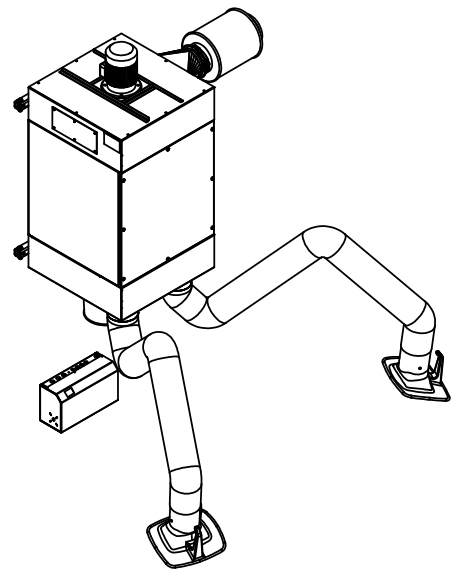
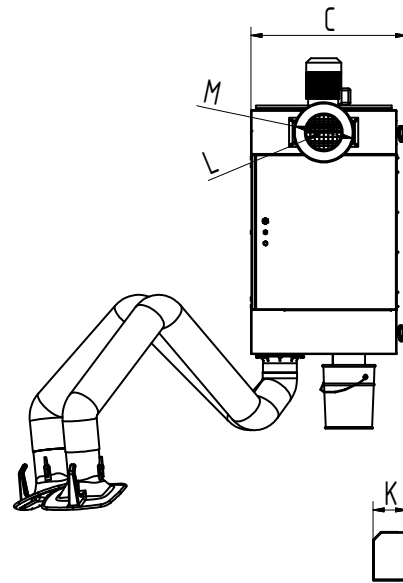
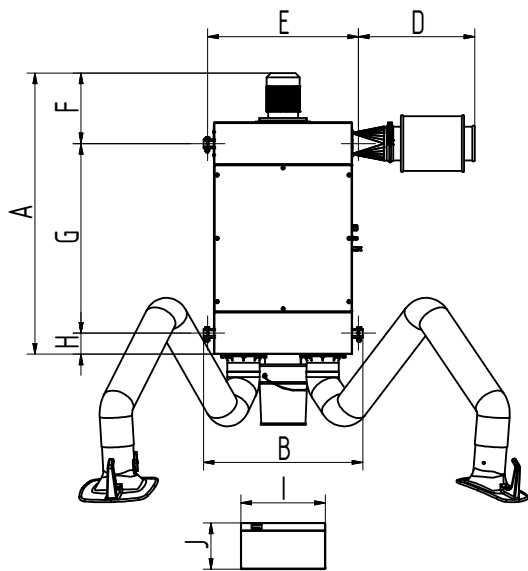

## Technical Data

### Dimensions

A	1332 mm
B	755 mm
C	701 mm
D	551 mm
E	715 mm
F	337 mm
G	898 mm
H	97 mm
I	400 mm
J	218 mm
K	151 mm
L	158 mm
M	271 mm