

WallMaster

Art. No.: 65 750



Technical Data

| Filter | |
|-----------------------------------|------------------------|
| Filter stages | 2 |
| Filter method | Storage Filter |
| Filter surface | 42 m ² |
| Type of filter | Safe Change Filter |
| Filter material | Non-woven polyester |
| Filter efficiency | > 99.5 % |
| Filter class | E12 |
| Basic data | |
| Dimensions (w x t x h) | 765 x 715 x 795 mm |
| Weight | 65 kg |
| Suitable for air volumes of up to | 1600 m ³ /h |

Applications

- Medium levels of smoke and dust
- Modular extension in combination with capturing elements
- One or two workplaces

Benefits

- Increased safety with safe filter change
- Very economic due to long lasting high capacity filters
- Inexpensive welding smoke filter for retrofitting of existing capturing elements
- Robust filter monitoring by means of pressure gauge

Properties

- Retrofittable
- Integrated lifting device for filter change
- Easy and quick installation
- Compact and solid design
- Mechanical operation of the filter unit



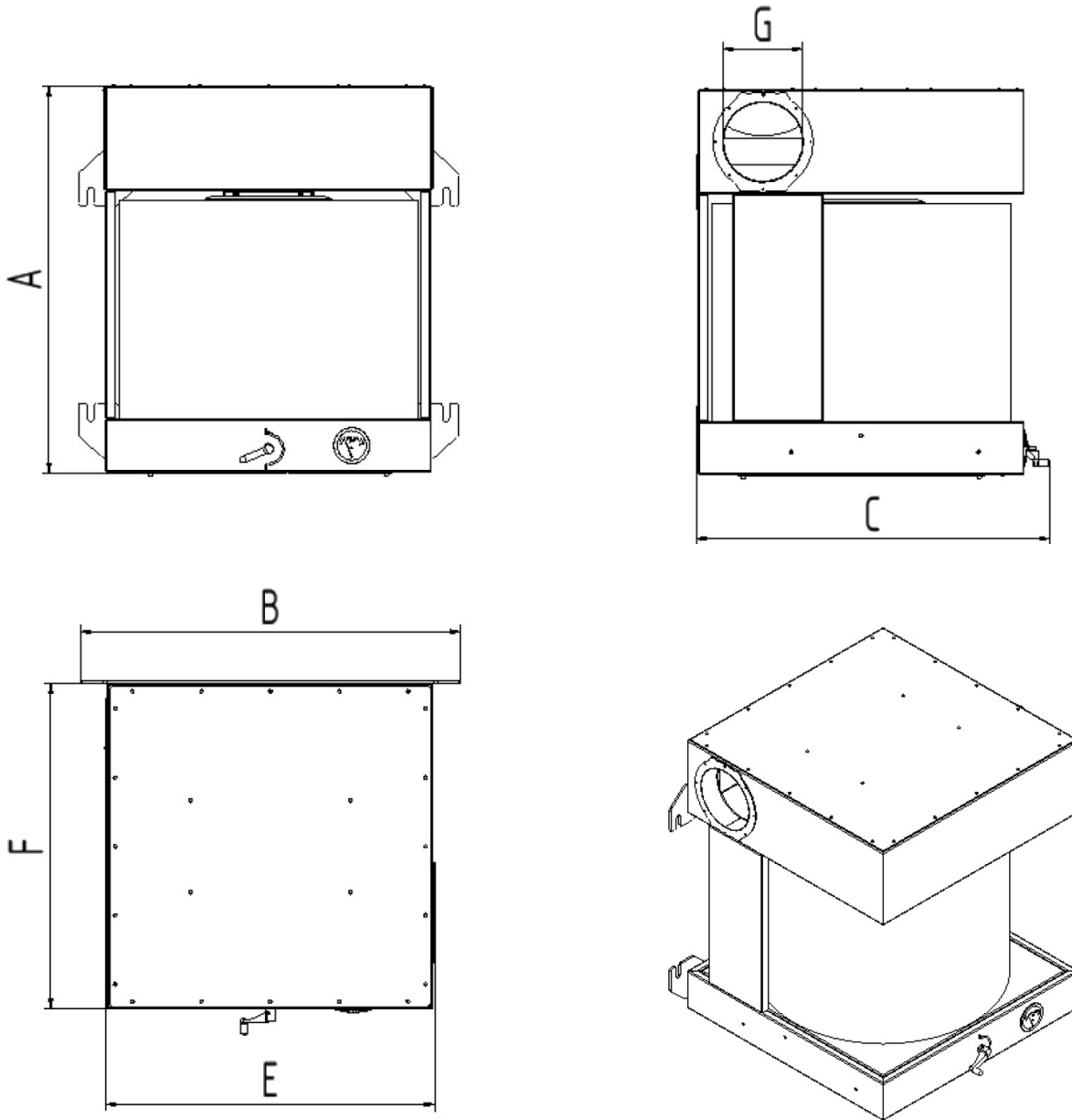

Technical Data

| Dimensions | |
|------------|--------|
| A | 795 mm |
| B | 765 mm |
| C | 715 mm |
| E | 660 mm |
| F | 660 mm |
| G | 160 mm |