

# VacuFil 2000

Art. No.: 82 820



## Applications

- High levels of smoke and dust
- Welding torch extraction, nozzles and high vacuum exhaust arms
- Large welding shops or training centres

## Benefits

- Easy installation since unit is delivered ready to plug in ("plug and play")
- Contamination-free dust collection due to compressed air fixation of dust collection containers
- Particularly space-saving system due to very compact design
- Uninterrupted continuous operation due to automatic differential pressure-controlled filter cleaning
- Considerable energy cost savings by using the automatic extraction volume control
- Convenient operation due to intelligent control via touch screen with diagnostic system
- Flexible integration of the control system into third-party systems such as cutting equipment due to potential-free contacts

## Properties

- Automatic filter cleaning, pressure-controlled
- Side channel blower
- Control via touch screen
- KemTex® ePTFE filter cartridges
- Dust collection container with pneumatic lifting device
- Preassembled and ready to plug in
- Automatic suction power regulation

## Accessories

- Silencer
- External On/Off
- Spark separator – SparkTrap



## Technical Data

### Filter

Filter stages	1
Filter method	Cleanable filter
Number filter elements	4
Filter surface total	40 m <sup>2</sup>
Filter material	PTFE-membrane
Filter efficiency	> 99.99 %
Dust classification	M

### Basic data

Extraction capacity	100 - 2000 m <sup>3</sup> /h
Vacuum	0 - 21000 Pa
Dimensions (w x t x h)	1470 x 1870 x 2575 mm
Weight	1125 kg
Motor power	22 kW
Power supply	3 x 400 V / 50 Hz
Rated current	40 A
Noise level	72 dB(A)

### Additional information

Fan type	Side channel blower, controlled by frequency inverter
Compressed air supply	5 - 6 bar
Air outlet	315 mm
Air intake	315 mm

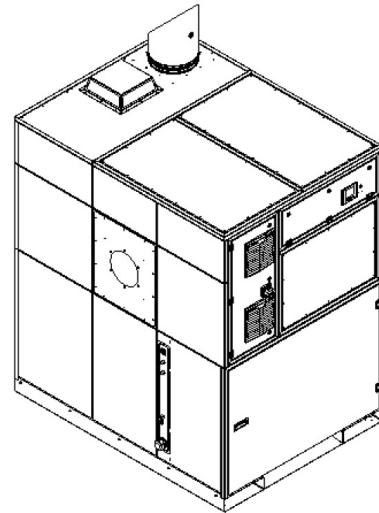
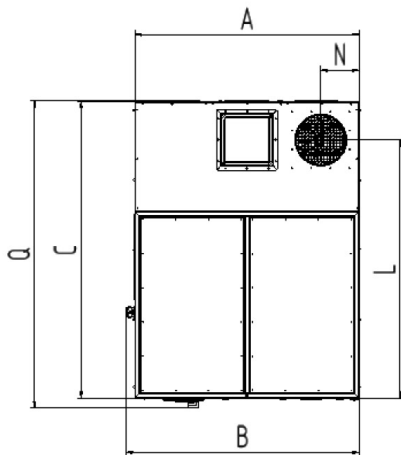
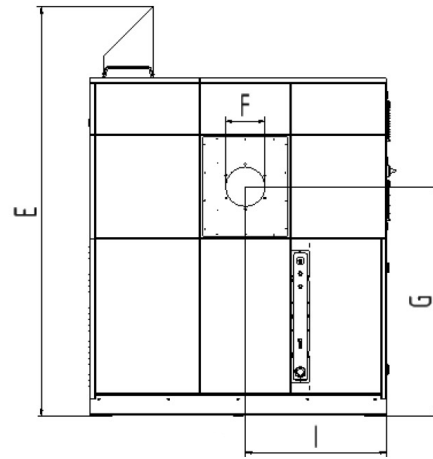
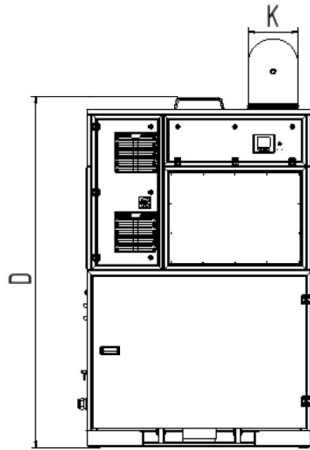

## Technical Data

### Dimensions

A	1415 mm
B	1470 mm
C	1867 mm
D	2200 mm
E	2575 mm
F	315 mm
G	1444 mm
I	889 mm
K	315 mm
L	1626 mm
N	242 mm
Q	1934 mm

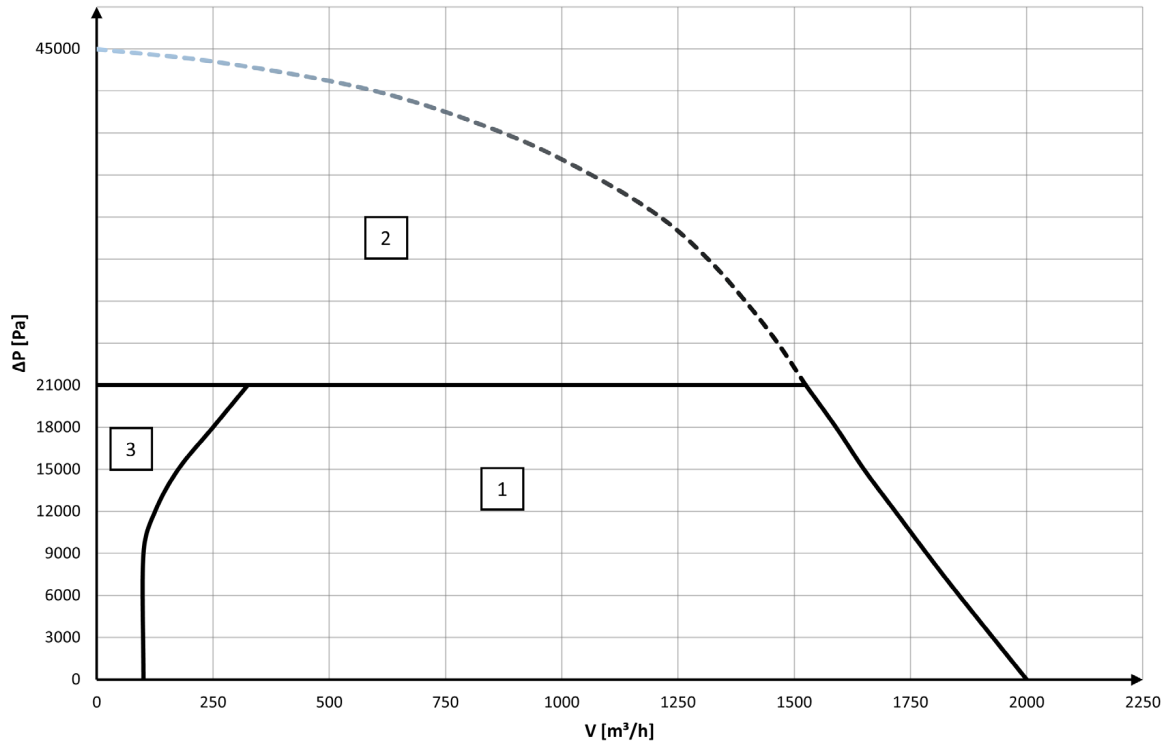

- 1. recommended working zone
- 2. electronic control zone
- 3. overheating zone