

# WeldFil Compact

Art. No.: 3420

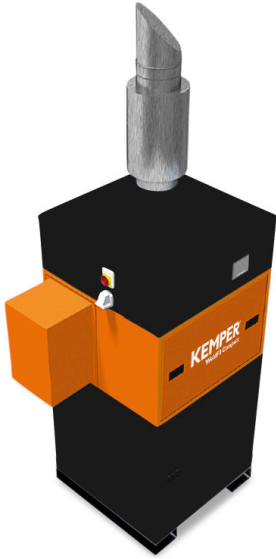

## Applications

- High levels of smoke and dust
- Welding and grinding shops
- Training centres and robotic welding lines
- Laser, plasma and flame cutting systems
- Can be installed outdoors

## Benefits

- Contamination-free dust collection due to compressed air fixation of dust collection containers
- Uninterrupted continuous operation due to automatic differential pressure-controlled filter cleaning
- Little noise emission due to a low noise level
- Quick and simple set up, delivered ready to plug in with forklift pockets and lifting eyes \*1
- Considerable energy cost savings by using the automatic extraction volume control
- Flexible integration of the control system into third-party systems such as cutting equipment due to potential-free contacts \*2
- Best health protection for employees by use of KemTex® ePTFE cartridges with surface filtration

## Properties

- Automatic filter cleaning, pressure-controlled
- Control via touch screen
- W3/IFA certified
- KemTex® ePTFE filter cartridges
- Dust collection container with pneumatic lifting device
- Automatic extraction volume control (optional)

## Accessories

- Automatic extraction volume control
- External On/Off
- Fleet management, remote maintenance and pre-noise maintenance using autarkic networking via mobile radio to the KEMPER cloud
- Spark separator – SparkTrap
- Weatherproof housing for outdoor installation

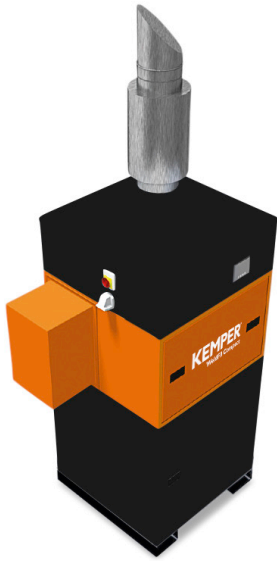

## Technical Data

### Filter

Filter stages	1
Filter method	Cleanable filter
Filter cleaning method	Rotating nozzle
Filter surface	108 ft <sup>2</sup>
Number filter elements	3
Filter surface total	323 ft <sup>2</sup>
Type of filter	Filter cartridge
Filter material	ePTFE membrane
Filter efficiency	> 99.99 %
Dust classification	M

### Basic data

Max. fan performance	1766 cfm
Extraction capacity	735 - 1271 cfm
Maximum vacuum	11 inch WC
Vacuum	11 - 8 inch WC
Weight	410 lbs
Motor power	4.02 hp
Power supply	3 x 400 V / 50 Hz
Rated current	6.5 A
Noise level	65 dB(A)

### Additional information

Fan type	Impeller, direct driven
Compressed air supply	73 - 87 PSI
Air outlet	9.8 in
Air intake	9.8 in
Capacity Dust collection container	9 gal

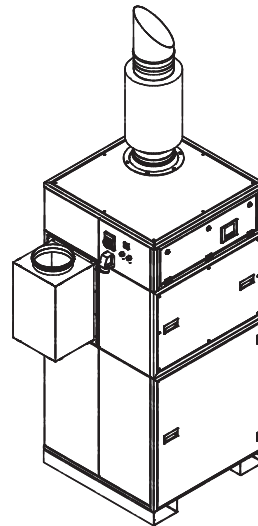
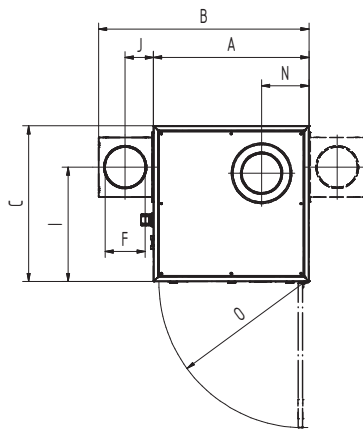
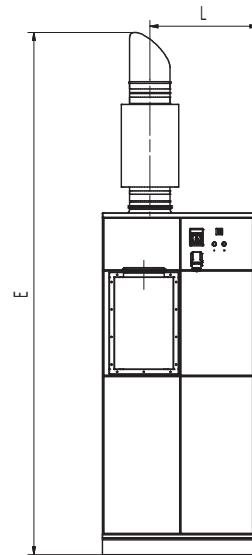
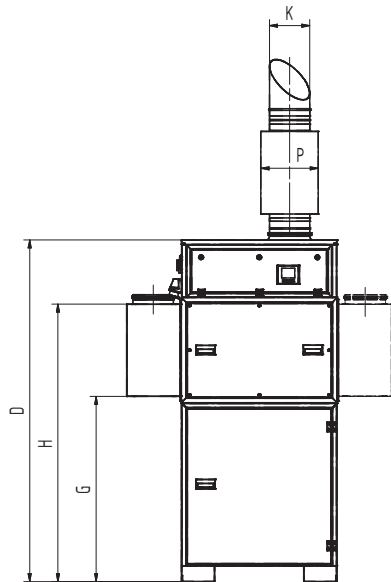

## Technical Data

### Dimensions

A	37.9 in
B	51.3 in
C	37.9 in
D	83.1 in
E	127.2 in
F	9.8 in
G	45.1 in
H	67.6 in
I	27.8 in
J	6.9 in
K	9.8 in
L	26.3 in
N	11.5 in
O	35.3 in
P	14 in

The shown transition pieces are optional

# Pressure-volume graph