

# WeldFil Compact

Art. No.: 3440 550

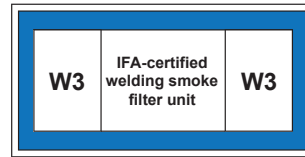

## Applications

- High levels of smoke and dust
- Welding and grinding shops
- Training centres and robotic welding lines
- Laser, plasma and flame cutting systems
- Can be installed outdoors

## Benefits

- Contamination-free dust collection due to compressed air fixation of dust collection containers
- Uninterrupted continuous operation due to automatic differential pressure-controlled filter cleaning
- Little noise emission due to a low noise level
- Quick and simple set up, delivered ready to plug in with forklift pockets and lifting eyes \*1
- Considerable energy cost savings by using the automatic extraction volume control
- Flexible integration of the control system into third-party systems such as cutting equipment due to potential-free contacts \*2
- Best health protection for employees by use of KemTex® ePTFE cartridges with surface filtration

## Properties

- Automatic filter cleaning, pressure-controlled
- Control via touch screen
- W3/IFA certified
- KemTex® ePTFE filter cartridges
- Dust collection container with pneumatic lifting device
- Automatic extraction volume control (optional)

## Accessories

- Automatic extraction volume control
- External On/Off
- Fleet management, remote maintenance and pre-noise maintenance using autarkic networking via mobile radio to the KEMPER cloud
- Spark separator – SparkTrap
- Weatherproof housing for outdoor installation



## Technical Data

### Filter

Filter stages	1
Filter method	Cleanable filter
Filter cleaning method	Rotating nozzle
Filter surface	108 ft <sup>2</sup>
Filter surface total	646 ft <sup>2</sup>
Type of filter	Filter cartridge
Filter material	ePTFE membrane
Filter efficiency	> 99.99 %
Dust classification	M

### Basic data

Max. fan performance	3237 cfm
Extraction capacity	1618 - 2330 cfm
Vacuum	11 - 7 inch WC
Weight	1389 lbs
Motor power	5.36 hp
Power supply	3 x 460 V / 60 Hz
Rated current	7.8 A
Noise level	65 dB(A)

### Additional information

Fan type	Impeller, direct driven
Compressed air supply	73 - 87 PSI
Air outlet	bool_false in
Air intake	bool_false in
Capacity Dust collection container	2 x 8 gal

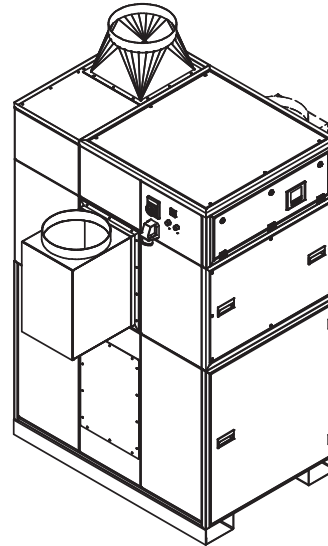
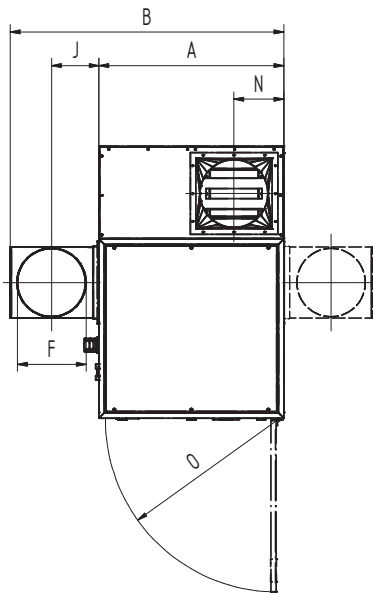
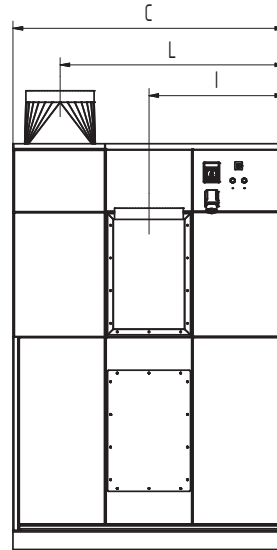
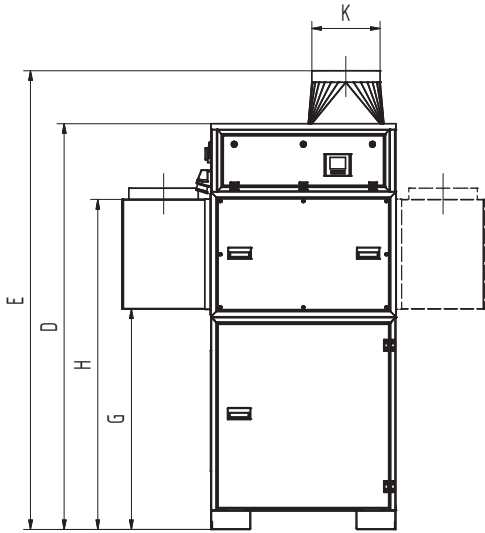

## Technical Data

### Dimensions

A	55.6 in
B	73 in
C	55.6 in
D	83.1 in
E	98.8 in
F	14 in
G	45.1 in
H	67.6 in
I	27.8 in
J	8.9 in
K	14 in
L	46.3 in
N	19.1 in
O	53 in

The shown transition pieces are optional

# Pressure-volume graph

- Fan characteristic curve
- Working pressure increase
- ▨ Recommended Use

$$\frac{\Delta P_{s\,tat.}}{Pa}$$

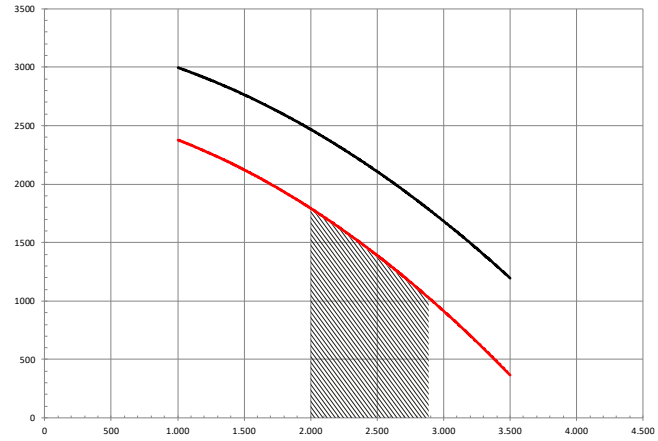

$$\vec{v} / m^3/h$$