

PlasmaFil Pro

Art. No.: 32 130 213



Applications

- High levels of smoke and dust
- Welding and grinding shops
- Training centres and robotic welding lines
- Laser, plasma and flame cutting systems
- Can be installed outdoors

Benefits

- Contamination-free dust collection due to compressed air fixation of dust collection containers
- Uninterrupted continuous operation due to automatic differential pressure-controlled filter cleaning
- Little noise emission due to a low noise level
- Quick and simple set up, delivered ready to plug in with forklift pockets and lifting eyes *1
- Considerable energy cost savings by using the automatic extraction volume control
- Convenient operation due to intelligent control via touch screen with diagnostic system
- Best health protection for employees by use of KemTex® ePTFE cartridges with surface filtration
- Recirculation is possible even when using chrome-nickel steel thanks to W3 certification

Properties

- KemTex® ePTFE filter cartridges
- Automatic filter cleaning on required basis
- Highly effective and uniform filter cleaning by means of rotary nozzle
- Control via compact touch information display
- Low noise emissions thanks to extremely low noise level
- Quick and easy installation thanks to user-friendly preparation
- Low space requirement due to compact design

Accessories

- Dosing unit for pre-coating the filter cartridges
- Automatic extraction volume control
- Fleet management, remote maintenance and pre-noise maintenance using autarkic networking via mobile radio to the KEMPER cloud
- Automatic start-stop
- Weatherproof housing for outdoor installation



Technical Data

Filter

Filter stages	1
Filter method	Cleanable filter
Filter cleaning method	Rotating nozzle
Filter surface	20 m ²
Number filter elements	13
Filter surface total	260 m ²
Type of filter	Filter cartridge
Filter material	ePTFE membrane
Filter efficiency	> 99.99 %
Dust classification	M

Basic data

Extraction capacity	9000 - 12960 m ³ /h
Vacuum	2250 - 1500 Pa
Weight	2320 kg
Motor power	11 kW
Power supply	3 x 400 V / 50 Hz
Rated current	20.6 A
Noise level	65 dB(A)

Additional information

Fan type	Radial fan, belt driven
Compressed air supply	5 - 6 bar
Air outlet	710 mm
Air intake	560 mm
Capacity Dust collection container	2 x 192 l

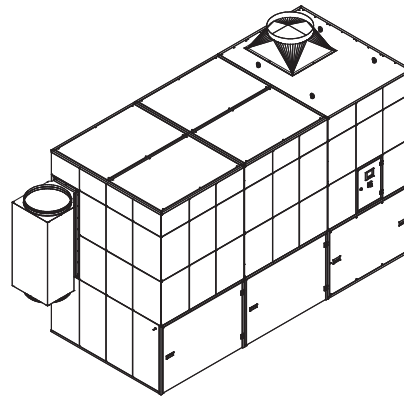
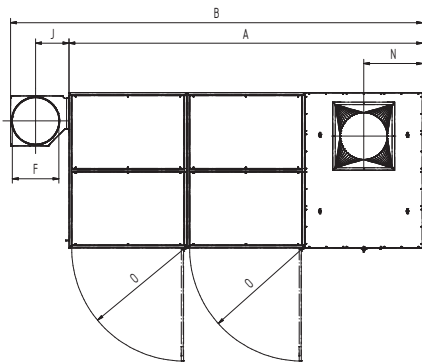
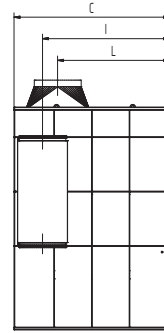
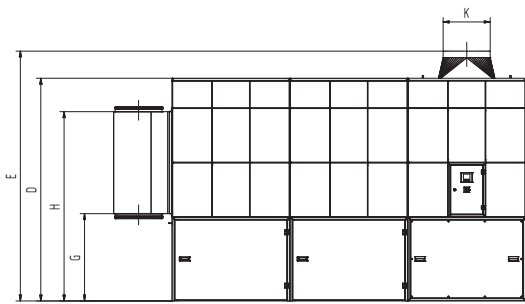

Technical Data

Dimensions

A	4239 mm
B	4939 mm
C	1864 mm
D	2670 mm
E	3020 mm
F	560 mm
G	1047 mm
H	2271 mm
I	1524 mm
J	400 mm
K	710 mm
L	1341 mm
N	707 mm
O	1347 mm

The shown transition pieces are optional

Pressure-volume graph

- Fan characteristic curve
- Working pressure increase
- ▨ Recommended Use

