

ArcFil Pro

Art. No.: 35 65



Applications

- High levels of smoke and dust
- Welding and grinding shops
- Training centres and robotic welding lines
- Laser, plasma and flame cutting systems
- Can be installed outdoors

Benefits

- Contamination-free dust collection due to compressed air fixation of dust collection containers
- Uninterrupted continuous operation due to automatic differential pressure-controlled filter cleaning
- Little noise emission due to a low noise level
- Quick and simple set up, delivered ready to plug in with forklift pockets and lifting eyes *1
- Considerable energy cost savings by using the automatic extraction volume control
- Best health protection for employees by use of KemTex® ePTFE cartridges with surface filtration
- Recirculation is possible even when using chrome-nickel steel thanks to W3 certification

Properties

- Control via touch screen
- KemTex® ePTFE filter cartridges
- Automatic extraction volume control (optional)
- Automatic filter cleaning on required basis
- Control via compact touch information display
- Low noise emissions thanks to extremely low noise level

Accessories

- Dosing unit for pre-coating the filter cartridges
- Automatic dust disposal - DustEvac
- Automatic extraction volume control
- Fleet management, remote maintenance and pre-noise maintenance using autarkic networking via mobile radio to the KEMPER cloud
- Automatic start-stop
- Weatherproof housing for outdoor installation



Technical Data

Filter

Filter stages	1
Filter method	Cleanable filter
Filter cleaning method	Rotating nozzle
Filter surface	10 m ²
Number filter elements	9
Filter surface total	90 m ²
Type of filter	Filter cartridge
Filter material	ePTFE membrane
Filter efficiency	> 99.99 %
Dust classification	M

Basic data

Extraction capacity	4500 - 6480 m ³ /h
Vacuum	2300 - 1750 Pa
Weight	790 kg
Motor power	5,5 kW
Power supply	3 x 400 V / 50 Hz
Rated current	10.7 A
Noise level	65 dB(A)

Additional information

Fan type	Radial fan, belt driven
Compressed air supply	5 - 6 bar
Air outlet	450 mm
Air intake	450 mm
Capacity Dust collection container	192 l

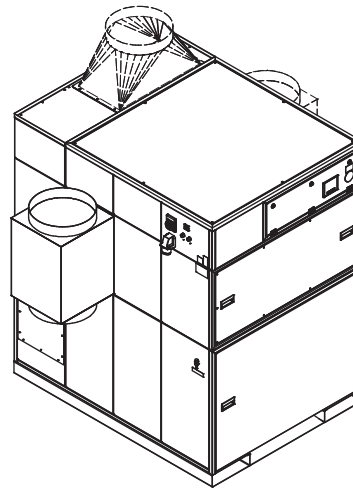
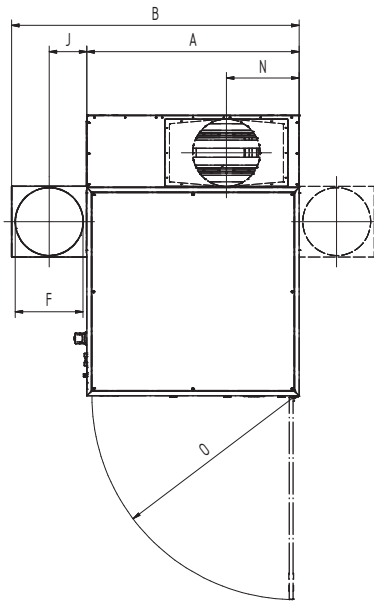
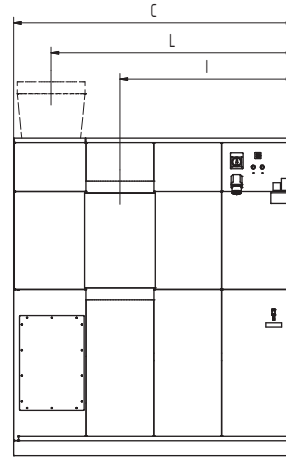
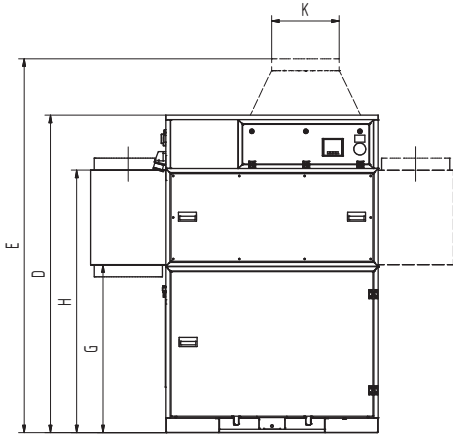

Technical Data

Dimensions

A	1413 mm
B	1913 mm
C	1864 mm
D	2110 mm
E	2510 mm
F	450 mm
G	1146 mm
H	1716 mm
I	1157 mm
J	235 mm
K	450 mm
L	1616 mm
N	484 mm
O	1347 mm

The shown transition pieces are optional

Pressure-volume graph

- Fan characteristic curve
- Working pressure increase
- ▨ Recommended Use

